

SanTRAL® NSU 30-3

dispenser for liquid soap and free-flowing hand cleaners • for refill
free choosable products • lockable

OPHARDT
hygiene

Ophardt Hygiene-Technik GmbH + Co. KG
Lindenau 27 • D-47661 Issum
Tel.: +49 2835 18-0 • Fax: +49 2835 18-77
E-Mail: info@ophardt.com • www.ophardt.com

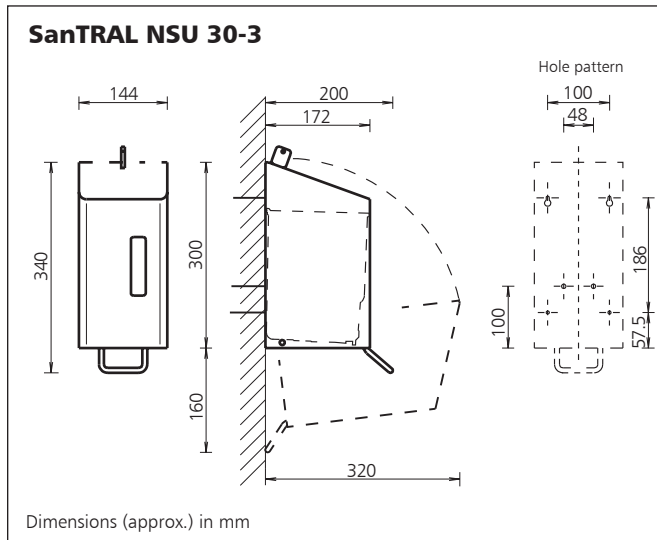

Soap dispenser

- ▶ for dosing of liquid and creamy soaps, washing-up liquids and free-flowing hand cleaners with friction agents

References:

- ▶ old people's-/nursing homes, hospitals, laboratories, large kitchen, food industry, industry, shopping centers, gastronomy and hotels, airports, penal institutions, schools, sport facilities, administrations

Place of application:

- ▶ washrooms, toilets, baths, care and medical rooms, kitchens, production sites, offices

Technical Data

Housing:	Stainless steel, brushed and ground or powder coated (white RAL 9010)
Window:	Plastic, clear
Dosing pump:	Plastic, ca. 3,0 ml/stroke
Operating lever:	Stainless steel
Lock:	Plastic (antivandalism function)
Key:	Plastic
Wall mounting:	4-point-suspension with four plugs and steel screws
Receptacle:	PP-refill receptacle, detachable

Description for tender

..... pcs. **SanTRAL NSU 30-3 P Art-No. 225300**
dispenser for liquid soaps and free-flowing hand cleaners, 3000 ml, stainless steel, powder coated (white RAL 9010), operating lever made of stainless steel, pressure application, special lock (antivandalism function), window for the level control, detachable refill receptacle, fillable with the product of your choice, housing with pitch of the roof against placing on the dispenser
Dimensions W 144 x H 340 x D 200 mm

..... pcs. **SanTRAL NSU 30-3 E Art-No. 1411078**
dispenser for liquid soaps and free-flowing hand cleaners, 3000 ml, stainless steel, brushed and ground, operating lever made of stainless steel, pressure application, special lock (antivandalism function), window for the level control, detachable refill receptacle, fillable with the product of your choice, housing with pitch of the roof against placing on the dispenser
Dimensions W 144 x H 340 x D 200 mm

Product: **SanTRAL®**
Manufacturer: OPHARDT HYGIENE-TECHNIK GmbH + Co. KG